



# GN

Thermoforming Equipment



# GN 580

*new*

# GN

Thermoforming Equipment

FORMING THE WORLD

## Specifications

### GN580 Specifications

Forming Area	580mm x 465mm (22.8" x 18.3") maximum
Depth of Draw (above and below sheet line)	120mm (4.7")
Clamping Force	25 Ton
Cutting Force	60 Ton
Sheet Width (Maximum)	650mm (25.6")
Material Thickness Range	0.18mm to 1.5mm (0.007" to 0.06")
Main Supply Voltage	3 Phase + N + PE, 50-60 HZ (380V-480V)
Air Pressure (minimum - maximum)	6 bar (87 PSI) - 8.3 bar (120 PSI)
Cycle Speed (maximum)	45 cpm
Machine Dimensions (l x w x h)	11588mm x 2742mm x 2592mm (38' x 8' 11" x 8' 6")
Machine Weight	12000 kg (26500 lbs)

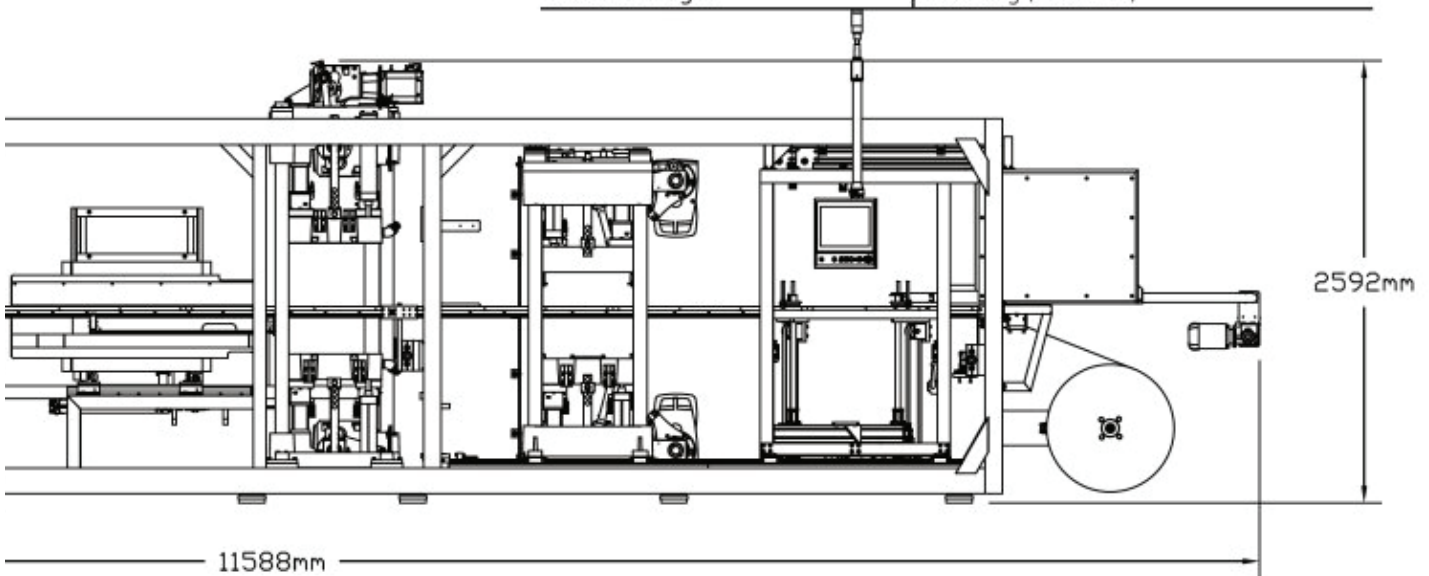

ALL SPECIFICATIONS SUBJECT TO CHANGE

## At the cutting edge

GN Thermoforming Equipment has set the world standard for the plastics industry by developing a complete line of robust and dependable thermoforming machines. GN machines are easy to use and ideally suited to produce high quality thermoformed plastic products from a variety of roll-fed thermoformable materials.

Continuous research and development are the cornerstones of GN's advanced technology. Our team of experienced engineers focuses on equipment design and continuous improvement based on customer feedback and industry trends.

GN ensures the productivity of its thermoforming machines with one of the industry's most comprehensive customer service programs. Our worldwide network of agents and qualified GN technicians are available to offer a reliable after sales service.

Leading plastic package manufacturers around the world have come to rely on GN Thermoformers to make their businesses more productive and profitable.

## GN580 Thermoformer

The **GN580** joins our line of Form/Cut/Stack Thermoformers. This High Speed model with integrated steel rule cutting press and stacking station is suitable for the cost-effective production of packaging made from all thermoformable materials.

The most distinctive features of the GN580 are the high degree of automation as well as the ease of tool change. This Thermoformer offers a variety of options to suit various customers' requirements. Further customization is also possible.

The **GN580** is suitable for Food, Industrial, Medical and a variety of other packaging applications. Contact your GN representative today!

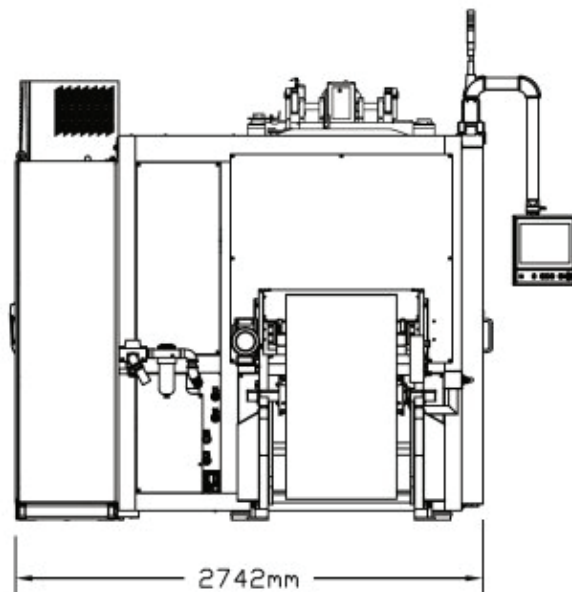

## Key Features

- High efficiency heaters
- Proven chain rail design
- Energy recovery system in all drives
- 3-shot standard oven with multi-zone heat
- Operator friendly HMI with integrated diagnostics and remote connection
- Maintenance-free precision roller bearings in toggles
- Tool cooling water purging system

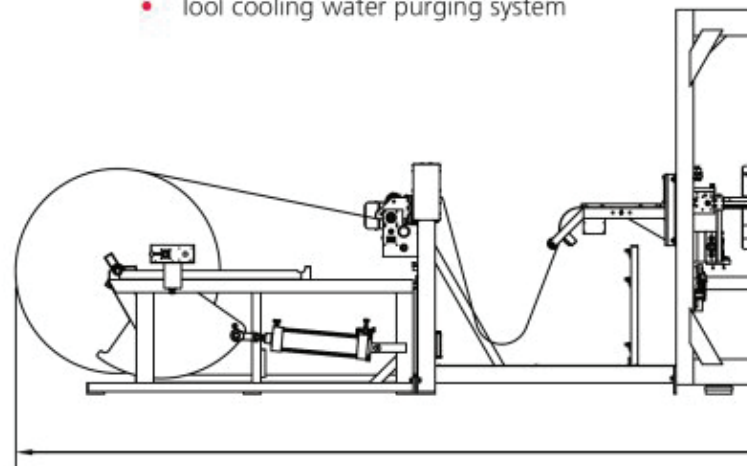

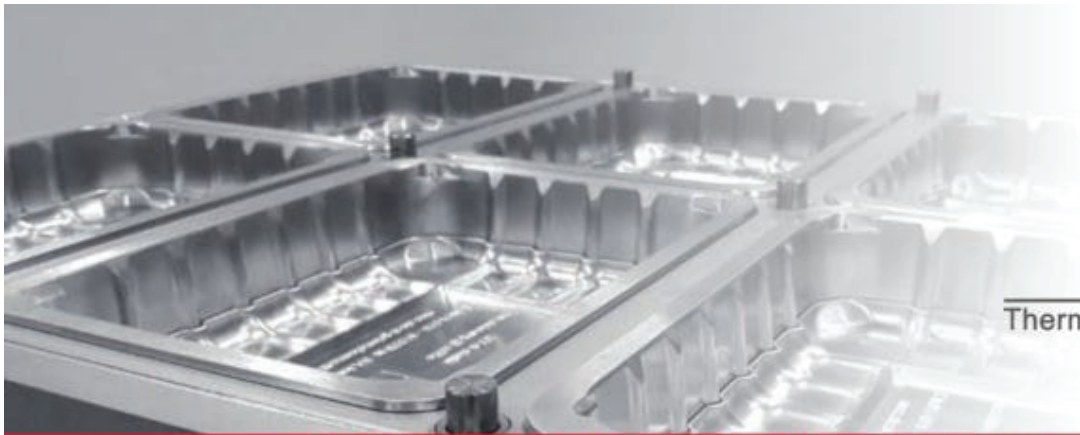

# GN

Thermoforming Equipment

**GN's Vision: Build Success With Our Customers!**

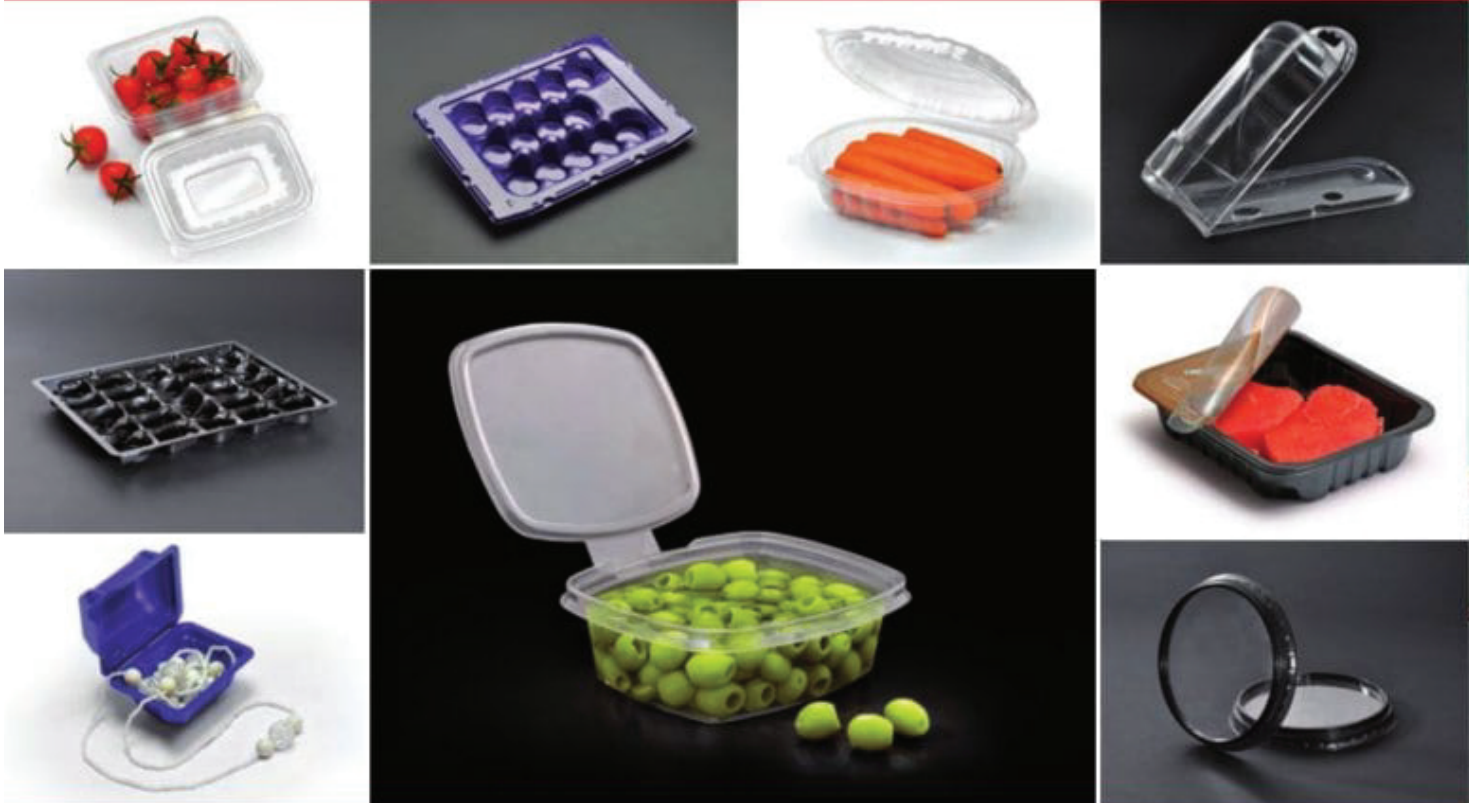

**Cost effective tooling is designed and production tested at our facility.**

### GN Thermoforming Equipment

PO Box 710, 345 Old Trunk 3  
Chester, Nova Scotia  
Canada B0J 1J0  
Tel +1-902/275 3571  
E-Mail [gn@gncanada.com](mailto:gn@gncanada.com)  
[www.gncanada.com](http://www.gncanada.com)

### GN Europe

Znojemská 64  
CZ - 586 01  
Jihlava  
Czech Republic  
Tel +420 567 313 078  
E-mail [gn@gneurope.com](mailto:gn@gneurope.com)

A world wide network of GN representatives  
is available to assist you.

ISO 9001-2015



Rev A